

Product Data Sheet: EL-150

Revision: 01

Date: 06 April 2004

Manufacturer: Secoh Sangyo Co. Ltd.

Product: Linear Diaphragm Air Pump

Series: EL Twin

Model/Type: EL-150

Technical Specifications:

Performance Data:

	EL-150	UNITS
Optimal Operating Pressure	0.25	Bar
Open Flow	265	l/min
Voltage	230	VAC
Maximum Power Consumption@200mbar	170	W
Frequency	50	Hz
Sound Level *	41	db (A)
Dimensions (L x W x H)	268.5 x 357 x 228	mm
Connection	27	Ø mm
Net Weight	16	kg

* Sound measured at a distance of 1.5 m

Pump Flow Performance Graph:

EL-150

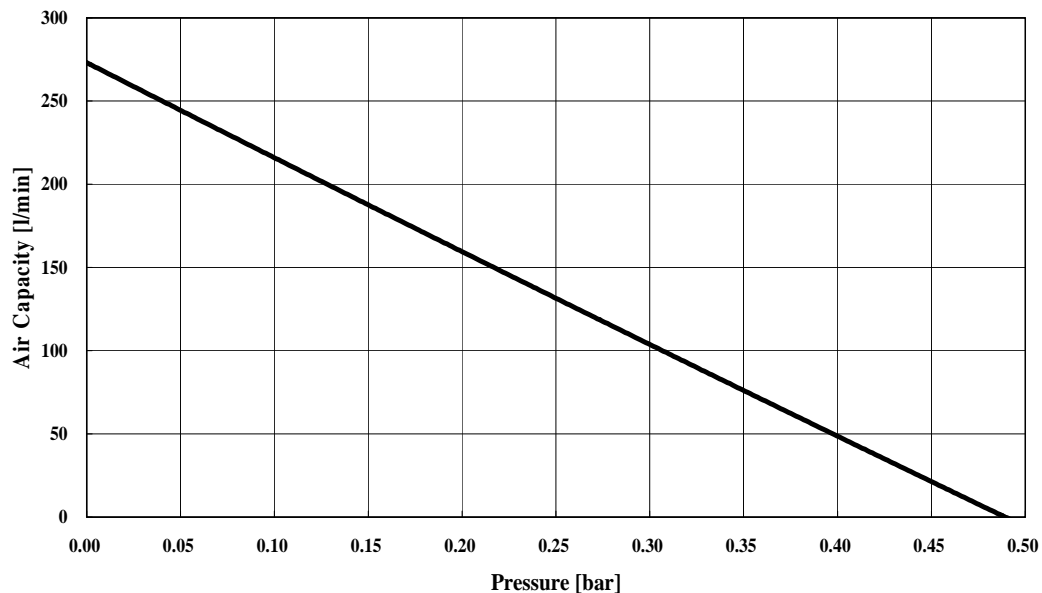

Dimensions:

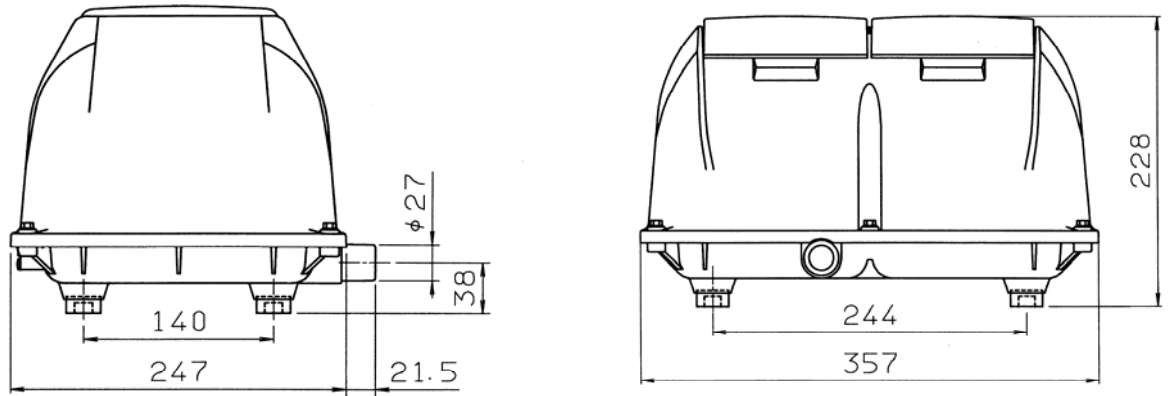

Key Benefits

Low noise level – 41 db (A)

Long life expectancy - Up to 35,000 hrs

Rainproof enclosure - Conforms to UL1450

Maintenance free - Just occasional filter change necessary

Low power consumption – Electromagnetic principle eliminates sliding parts, offering high efficiency

Oil-Free – Guarantees contamination free airflow

Low vibration – Pump casing separated from outer casing by isolastic anti vibration mounts

Very little pulsation – Smooth airflow delivery

CE compliant – Conforming to European legislation

Installation and operation

Installation:

The pump must always be installed above the water level. If the pump is set below the back flowing of the water may cause an electrical short circuit, leading to leakage and premature pump failure.

The pump must be located on a level platform to prevent biased strain on the diaphragms that could lead to reduced component life of the blower.

Environment:

Ensure that the unit has good ventilation, especially when subjected to severe operating conditions. If installed in a cabinet, sufficient ventilation (louvered vents) is essential to prevent overheating. A cool ambience will ensure longer diaphragm and valve life.

The pump should not be operated in a dusty environment. Overheating due to blocked filter elements may shorten the life of the diaphragms and valves. Where the air is dirty, corresponding filters should be provided.

Medium Quality:

The pumps were specially developed for transporting air. The atmosphere humidity should not be higher than 90%. Inflammable or aggressive gases and vapours should not enter the pump as the flow path leads to current carrying parts. A requirement for transporting gases or vapours is that the medium has been previously tested to their resistance and operating safety. This test must take place on the initiative of the user.

Piping:

Select tube size, lengths and accessories to keep the pressure loss as small as possible, in particular:

- Make the piping as short and straight as possible
- Do not use tubing of smaller diameter than the port of the unit, inside Ø min. 27 mm for EL twin units
- Utilize large valves of smaller diameter than the blower's connector port. Use check valves that provide the lowest pressure drop rather than spring loaded valves.
- Select low air loss diffusers for aeration.

Maintenance:

Apart from occasional (but regular) filter cleaning and the simple replacement of some components, such as broken diaphragms, long term maintenance free operation is ensured. Complete service kits are available from www.partsandpumps.co.uk.

Storage:

The pumps may not be stored at less than -10°C. The permanent magnet would be weakened in such a case, and the performance may be affected.

The pump may not be stored in direct sunlight or at high temperatures as the rubber parts may age prematurely.

Guarantee:

12 months works guarantee