



WHIRLWINDTM

Septic Tank Aerator



- **Low Noise Level**
- **Low Power Consumption**
- **Easy Maintenance**
- **No Lubricator Required**

Thank you for purchasing our products. They are manufactured to the highest quality. Please refer to this manual for recommended maintenance, operational and safety instructions.

WARNING

FOR REPLACEMENT OR CHANGE OF ANY PARTS IN THE SERVICE MANUAL, WE SUGGEST YOU CONTACT AN AUTHORIZED TECHNICIAN.

DANGER

To avoid possible electric shock, especially when used in aquarium applications do not attempt repairs yourself, return the air pump to an authorized service facility, place of purchase or discard the pump.

1. If the pump falls into the water, DO NOT REACH FOR IT. Shut off the fuse or circuit breaker supplying power to the unit, retrieve it, and throw the pump away.
2. It should NOT be plugged in if there is water on or inside the unit.
3. Do not operate if the cord or plug is damaged, or if the unit has been dropped or damaged in any way.
4. To prevent the plug or electrical outlet from getting wet, position the aquarium tank and stand to one side of a wall-mounted outlet. A "drip loop" shown in Figure 1, should be used for each cord connecting an air pump to an electrical unit. The "drip loop" is that part of the cord below the level of the outlet or connector if an extension cord is used. The "drip loop" prevents water traveling along the cord and coming into contact with outlet. If the plug or outlet does get wet, DO NOT UNPLUG THE CORD; Disconnect the fuse or circuit breaker supplying power to the unit. Then unplug and examine for the presence of water in the outlet.
5. Do not use the pump near volatile liquids such as gasoline, thinners, etc., the unit could explode.
6. Close supervision is necessary when an appliance is used by or near children.
7. This pump is intended to deal with clean, dry air only. Do not attempt operation with water or other liquids.
8. The ambient operating temperature for this pump is between 41°F (5°C) and 104°F (40°C). Operation of pump in temperature range may result in malfunction or severely shortened service life.
9. Do not block the air being discharged. Be sure your diffuser is not clogged and septic tank is cleaned regularly (3-4 years min).
10. Always unplug pump prior to servicing. Grasp plug to remove cord from outlet. Do not remove by pulling on power cord.
11. Do not use the air pump for other than intended use. The use of attachments not recommended or not sold by the air pump manufacturer may cause an unsafe condition.
12. Do not install pump where it will be exposed to weather, do not store pump in temperatures below freezing.
13. Ensure pump is securely mounted prior to operation.
14. Read and observe all important markings on pump.
15. Ensure that extension cords (if required) have the correct or higher rating (amperes or watts). Ensure cord & unit are properly positioned off the ground and above high water due to rain.
16. To avoid injury, do not touch moving parts or hot parts such as heaters, reflectors and lamp bulbs which may warm the unit.
17. Always unplug unit before putting on or taking off parts or cleaning.

SAVE THESE INSTRUCTIONS

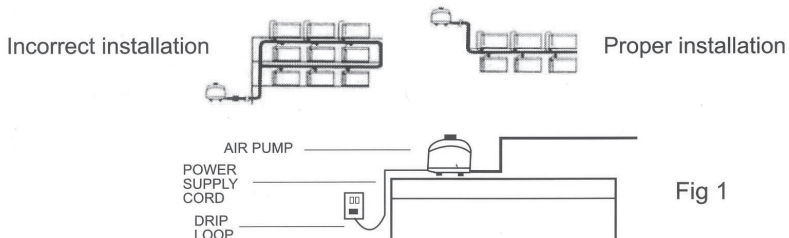

INSTALLATION

Disconnect electrical power at the fuse box or circuit breaker before installing this product. Install this product where it will not come into contact with water or other liquids. Install this product where it will be weather protected. Electrically ground this product. Failure to follow these instructions can result in death, fire or electrical shock.

CORRECT INSTALLATION IS YOUR RESPONSIBILITY

Make sure you have the proper installations conditions and that your diffuser is not clogged and tank pumped.

MOUNTING

This product must be installed on a flat, horizontal surface. Mounting the product to a stable, rigid operating surface and using shock mounts will reduce noise and vibration.

PLUMBING

Connect with pipe and fittings or rubber hose that are the same size or larger than the unit's outlet connection.

ACCESSORIES

Install relief valve and gauge at outlet to monitor performance. A check valve may be required to prevent backups into the unit.

MOTOR CONTROL

It is your responsibility to contact a qualified electrician and assure that the electrical installation is adequate and in conformance with all national and local codes and ordinances.

ELECTRICAL CONNECTION

This product must be properly grounded. Do not modify the plug provided. If it will not fit the outlet, have the proper outlet installed by a qualified electrician.

MODEL WITH A POWER SUPPLY CORD

This product must be grounded. For 120-volt circuit connect power supply cord grounding plug to a matching grounded outlet. Do not use an adapter.

In the event of an electrical short circuit, grounding reduces the risk of electric shock by providing an escape wire for the electric current. This product may be equipped with a power supply cord having a grounding wire with an appropriate grounding plug. The plug must be plugged into an outlet that is properly installed and grounded in accordance with all local codes and ordinances.

Check with a qualified electrician or serviceman if the grounding instructions are not completely understood, or if you are not sure whether the product is grounded. Do not modify the plug provided. If it will not fit the outlet have the proper outlet installed by a qualified electrician.

MODEL THAT IS PERMANENTLY WIRED

This product must be connected to a grounded, metallic, permanent wiring system or an equipment grounding terminal or lead on the product.

Power supply wiring must conform to all required safety codes and be installed by a qualified person. Check that supply voltage agrees with that listed on product nameplate.

EXTENSION CORDS

Use only a 3-wire extension cord that has a 3-blade grounding plug. Connect extension cord plug to a matching 3-slot receptacle. Do not use an adapter. Make sure your extension cord is in good condition. Check that the wire gauge of the extension cord is the correct size wire to carry the current this product will draw. An undersized cord is a potential fire hazard, and will cause a drop in line voltage resulting in loss of power causing the unit to burn up. DIAGRAM A indicates the correct gauge cord for length required and the ampere rating listed on the product nameplate. If in doubt, use the next heavier gauge cord. The smaller the gauge number, the heavier the cord.

DIAGRAM A - Minimum Gauge For Extension Cords

Amps	Volts	Length of cord in feet										
		25	50	100	150	200	250	300	400	500		
	120V	25	50	100	150	200	250	300	400	500		
	240V	50	100	200	300	400	500	600	800	1000		
0-2		18	18	18	16	16	14	14	12	12	G A U G E	
2-3		18	18	16	14	14	12	12	10	10		
3-4		18	18	16	14	12	12	10	10	8		
4-5		18	18	14	12	12	10	10	8	8		
5-6		18	16	14	12	10	10	8	8	6		

OPERATION

Use only recommended parts acceptable for pressure of at least 10 psi. When used, motor covers must be in place for safe operation. Product surfaces may become hot during operation. Do not direct air at a person or animal. Wear proper eye protection. Do not use around flammable or combustible liquid or gas. Failure to follow these instructions can result in burns, eye injury or other serious injury.

It is your responsibility to operate this product at recommended pressure duty and room ambient temperature.

START UP

If pump fails to start or slows down significantly under load, shut off and disconnect from power supply. Check that the voltage is correct for the pump and that your diffuser in the septic tank is clean and tank is pumped regularly (3-4 yrs min).

MAINTENANCE

Disconnect electrical power supply cord before performing maintenance on the unit. If product is hard wired into system, disconnect electrical power at the circuit breaker or fuse box before performing maintenance on the unit. Failure to follow these instructions can result in death, fire or electrical shock. Unit surfaces may become hot during operation; allow unit surfaces to cool before handling. Do not direct air stream at any person or animal. Wear proper eye protection. Clean the unit in a well-ventilated area. Failure to follow these instructions can result in burns, eye injury or other serious injury.

IT IS YOUR RESPONSIBILITY TO:

- Regularly inspect and make necessary repairs to product in order to maintain proper operation.
- Make sure that pressure is released from product before starting maintenance.
- Never add oil.

Check intake filter after first 500 hours of operation. Clean filter and adjust frequency for your situation This maintenance will help to assure the units performance and service life.

CLEANING

Do not use any other combustible solvent to clean unit.

1. Remove filter and clean using detergent and water only.
2. Rinse filter well and air dry.

Check that all external accessories work, relief valves and gauges are attached securely and are not damaged before re-operating unit.

TROUBLE SHOOTING

See Diagram B, page 4.

Diagram B

PROBLEM

CAUSE

ACTION TAKEN

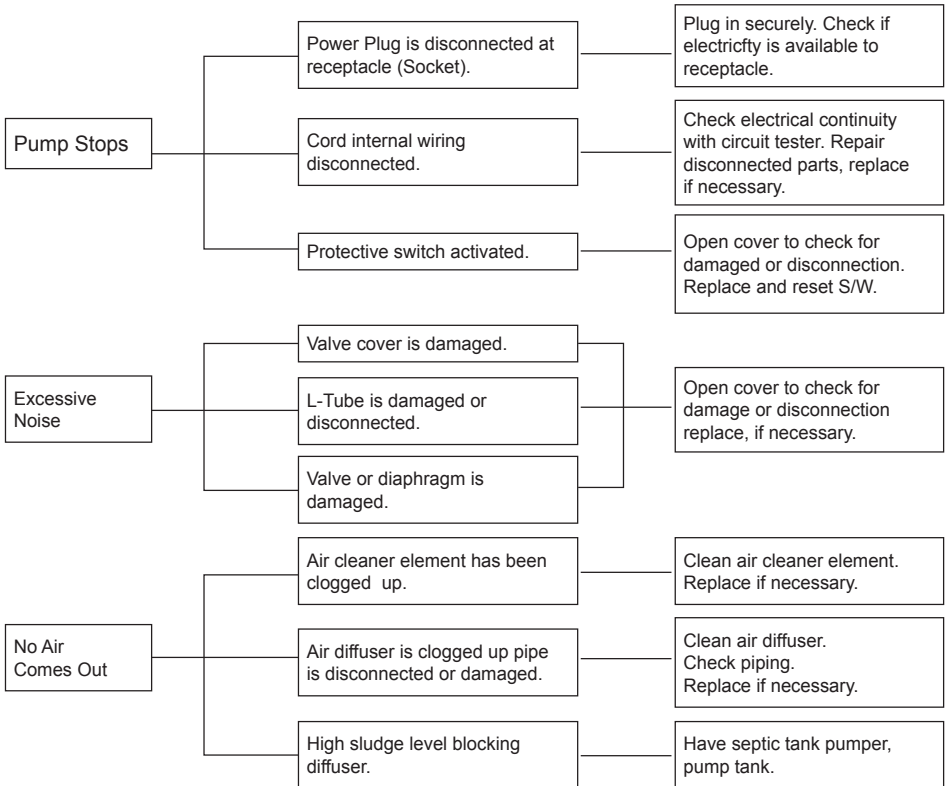

The Whirlwind STA Series Air Pump Alarm Operation Guide			
Alarm Function	To monitor pump and pressure loss.		
3-stage switch (Direction: left to right)	Position: Left	Position: Middle	Position: Right
	Function: Test alarm	Function: Monitor pump pressure	Function: Monitor pump pressure
Signal result (light & buzzer)	Result: Always Light on. Always Buzzer on. (See action note 1)	Result: Light on(pump pressure under 5 kpa). Buzzer off. (See action note 2)	Result: Both Light & Buzzer on (pump pressure under 5kpa). (See action note 3)
Action	1. No action required. It's only to check if the light and buzzer is normal.		
	2. Check for damaged pipe from pump to diffuser. Replace diaphragms or other parts.		
	3. Check for damaged pipe from pump to diffuser. Replace diaphragms or other parts.		
Comments	Alarm pressure is factory set. Do not adjust.		

Assembly Diagram for WHIRLWIND STA 40/60/80 (AL)

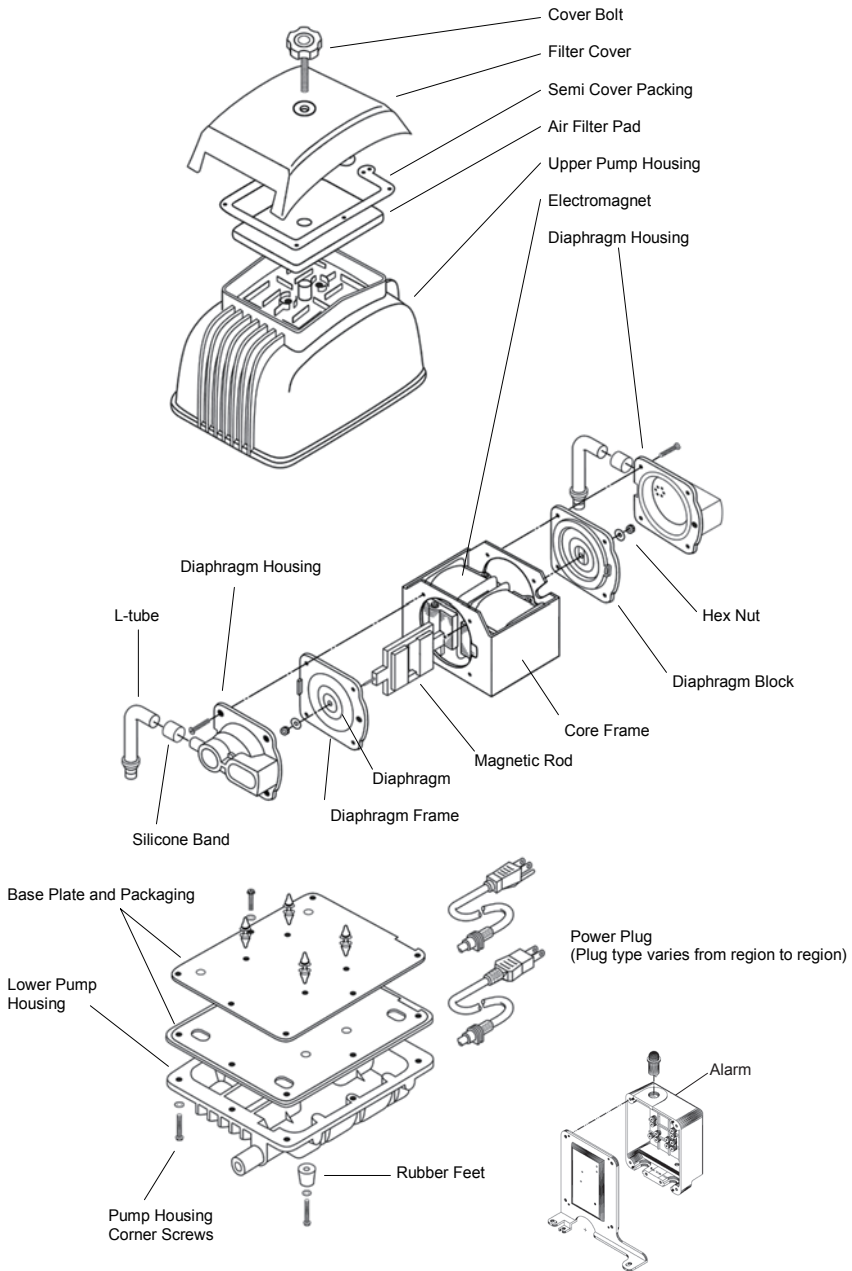

Assembly Diagram for WHIRLWIND STA 100/120/150/200

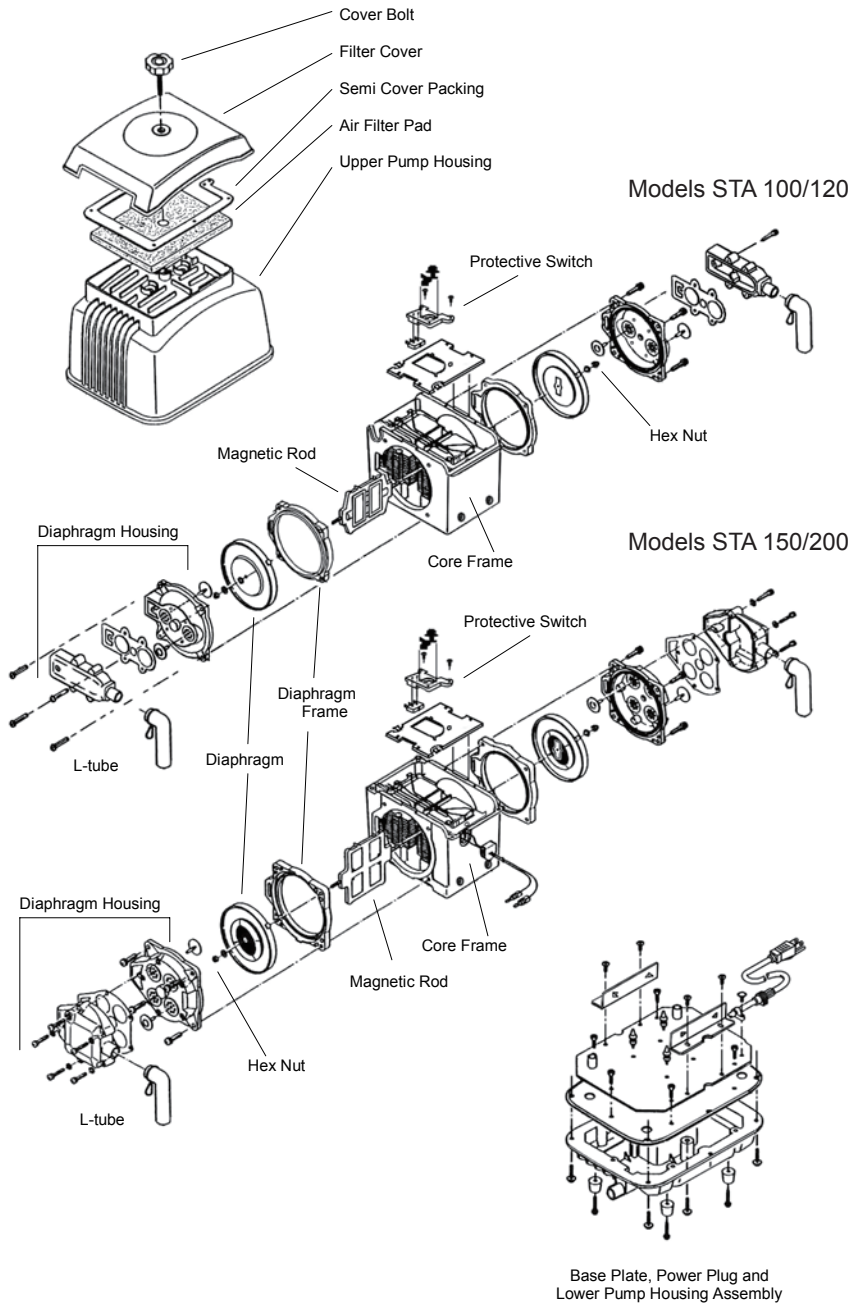

WARRANTY

Warranty policy covers the mechanical parts for two years, but to utilize the performance of the pumps, a change of diaphragm once a year is absolutely necessary for users.

The WHIRLWIND carries a 2 year warranty from the date of purchase provided that:

- It is operated in accordance with the instruction manual.
- Any repairs to the pump, which must be accompanied by this certificate, are performed by the dealer from which it was purchased.

Although the warranty period may not have expired, payment for repairs must be made in the following cases:

- When the fault is due to improper usage or repairs have been attempted by persons other than an authorized dealer.
- When due to fire, natural disaster, water damage, excessive back pressure or incorrect voltage.
- If the warranty card has been lost, incorrectly completed or details fraudulently changed.

Please read this Manual and save for future reference.

This pump is an Oil-less compressor requiring NO lubrication.

Consult your supplier before using at high altitudes.



Whirlwind is a registered trademark of
Septic Services, Inc.

Tel: 636-583-5564 Fax 636-583-6432